



# MMIC WIDEBAND Bias Tee

## MBT-283+

50Ω 1.5 to 28 GHz

### THE BIG DEAL

- Ultra Wideband, 1.5 to 28 GHz
- Very Low Insertion Loss, 0.7 dB typ.
- Good Return Loss, 20 dB typ.
- Excellent Isolation, 47 dB typ.

### APPLICATIONS

- Biasing Amplifiers
- Biasing Laser Diodes
- Biasing of Active Antennas

### PRODUCT OVERVIEW

Mini-Circuits' MBT-283+ is an ultra-wideband MMIC surface mount bias tee covering applications from 1.5 GHz to 28 GHz with low insertion loss, excellent return loss, and high DC-RF isolation over its entire frequency range. This model is capable of handling up to +30 dBm (1W) RF input power and DC input current up to 500mA. MBT-283+ is enclosed in a 3.5 x 2.5mm, 16-lead MCLP package for good thermal performance.

### KEY FEATURES

Feature	Advantages
Ultra-Wideband, 1.5 to 28 GHz	Supports a wide range of applications with a single device, including biasing broadband amplifier, laser diodes, active antennas and more.
Low Insertion Loss, 0.7 dB typ.	Minimizes RF leakage and interference with other elements in the system.
Excellent Return Loss, 20 dB typ.	Provides excellent matching for 50 Ohm system with minimal signal reflection
RF power handling up to 1W	This model supports applications with a variety of power requirements.
Excellent DC-RF isolation <ul style="list-style-type: none"> <li>• 59 dB, 1.5 to 10 GHz</li> <li>• 47 dB, 10 to 20 GHz</li> <li>• 48 dB, 20 to 28 GHz</li> </ul>	Minimizes RF Leakage and Interference with other elements in the system.

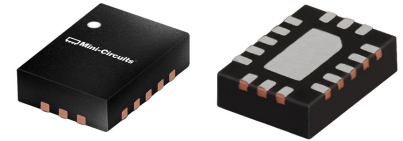

Generic photo used for illustration purposes only

CASE STYLE: JV2579

#### +RoHS Compliant

The +Suffix identifies RoHS Compliance. See our web site for RoHS Compliance methodologies and qualifications



# MMIC WIDEBAND Bias Tee

## MBT-283+

Mini-Circuits

### ELECTRICAL SPECIFICATIONS<sup>1</sup> AT 25°C, UNLESS NOTED

Parameter	Frequency (MHz)	Min.	Typ.	Max.	Units
Frequency Range		1500		28000	MHz
Insertion Loss	1500 - 10000	-	0.7	1.3	dB
	10000 - 20000	-	0.7	1.6	
	20000 - 25000	-	0.7	1.8	
	25000 - 28000	-	1.0	2.1	
Isolation (RF Port to DC Port)	1500 - 10000	-	57	-	dB
	10000 - 20000	-	47	-	
	20000 - 25000	-	48	-	
	25000 - 28000	-	47	-	
Return Loss	1500 - 10000	-	19	-	dB
	10000 - 20000	-	21	-	
	20000 - 25000	-	16	-	
	25000 - 28000	-	14	-	
DC resistance from DC to RF & DC port		-	2.7	-	Ohm

1. Measured on Mini-Circuits Characterization test Board TB-MBT-283+. See Characterization Test Circuit. (Figure 1)

### MAXIMUM RATINGS<sup>2</sup>

Parameter	Ratings
Operating Temperature	-40°C to 85°C
Storage Temperature	-65°C to 150°C
RF Power at DC & RF Port	30 dBm
Voltage at DC Port	35V
Current at DC Port	500 mA

2. Permanent damage may occur if any of those limits are exceeded.  
Electrical maximum ratings are not intended for continuous normal operation.



# MMIC WIDEBAND Bias Tee

## MBT-283+

### SIMPLIFIED SCHEMATIC AND PAD DESCRIPTION

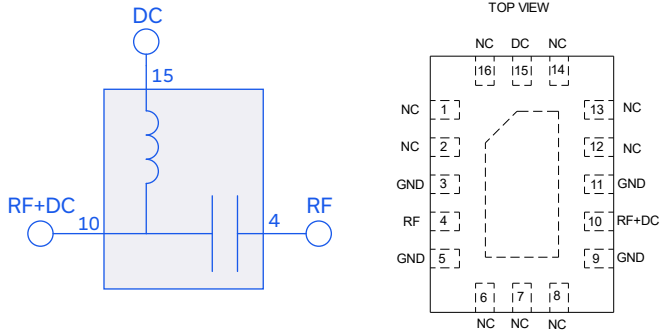

### PAD CONNECTIONS

Function	Pad Number	Description (Fig. 1)
RF	4	RF Pad
RF + DC	10	RF + DC Pad
DC	15	DC Pad, Connects DC Port Via C1
N/C	1,2, 6-8, 12-14 & 16	No connection, grounded on Test Board.
GROUND	3,5,9,11, & Paddle	Ground

### CHARACTERIZATION TEST & APPLICATION CIRCUIT

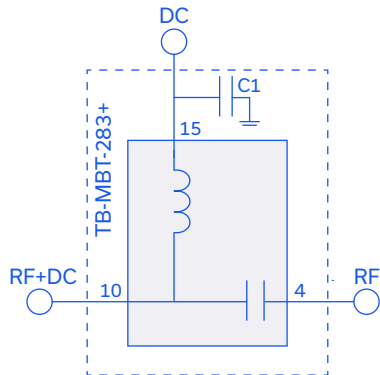

Component	Value	Size	Part Number	Manufacturer
C1	100pF	0402	GRM1555C1H101JA01D	Murata

Fig 1. Block Diagram of Test Circuit used for characterization. Test Board TB-MBT-283+  
Parameter to measure: Insertion Loss, Isolation, Return Loss  
Condition: Pin = 0 dBm

### PRODUCT MARKING

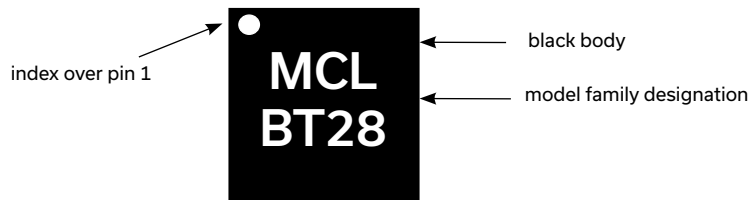

Marking may contain other features or characters for internal lot control



# MMIC WIDEBAND Bias Tee

## MBT-283+

Mini-Circuits

ADDITIONAL DETAILED TECHNICAL INFORMATION IS AVAILABLE ON OUR DASH BOARD. TO ACCESS [CLICK HERE](#)

Performance Data	Data Table Swept Graphs S-Parameter (S3P Files) Data Set (.zip file)
Case Style	JV2579 Plastic package, exposed paddle, lead finish: Matt Tin Plate
Tape & Reel Standard quantities available on reel	F104 7" reels with 2000 devices
Suggested Layout for PCB Design	PL-692
Evaluation Board	TB-MBT-283+ & TB-MBT-283C+
Environmental Ratings	ENV08T1

### ESD RATING

Human Body Model (HBM): Class 1B (500 V) in accordance with ANSI/ESD STM 5.1 - 2001

### MSL TEST FLOW CHART

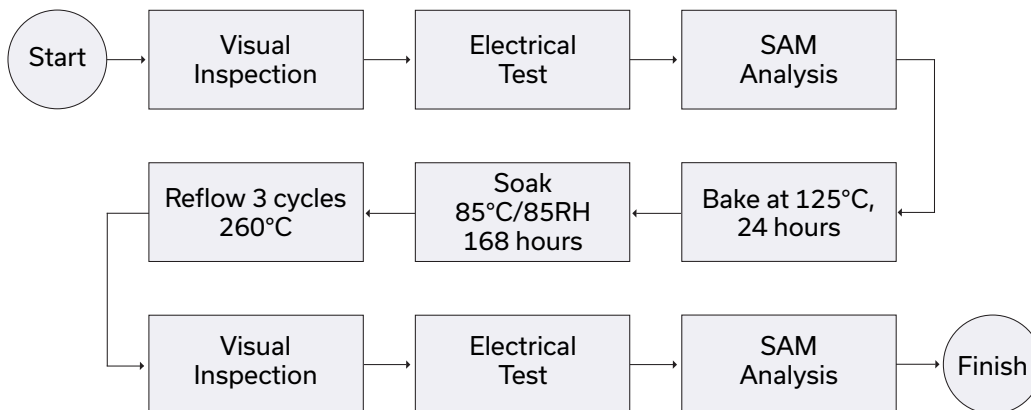

- NOTES**
- A. Performance and quality attributes and conditions not expressly stated in this specification document are intended to be excluded and do not form a part of this specification document.
  - B. Electrical specifications and performance data contained in this specification document are based on Mini-Circuit's applicable established test performance criteria and measurement instructions.
  - C. The parts covered by this specification document are subject to Mini-Circuits standard limited warranty and terms and conditions (collectively, "Standard Terms"); Purchasers of this part are entitled to the rights and benefits contained therein. For a full statement of the standard. Terms and the exclusive rights and remedies thereunder, please visit Mini-Circuits' website at [www.minicircuits.com/MCLStore/terms.jsp](http://www.minicircuits.com/MCLStore/terms.jsp)

